



# Newton's Third Law

## Topic

Newton's third law



Time

1 hour



Safety

Please click on the safety icon to view safety precautions.

## Materials

three long cylinder-shaped balloons  
fishing line 30 ft in length  
three drinking straws

masking tape  
two chairs

## Procedure

1. Cut three lengths of fishing line at least 10 ft long.
2. Tie one end of each fishing line to the back of a chair.
3. Place the chairs a minimum of 3 ft from each other.
4. Thread a drinking straw onto each one of the lines.
5. Attach the other end of the fishing line to another chair. Repeat for all the lines (see figure 1).

**Figure 1**

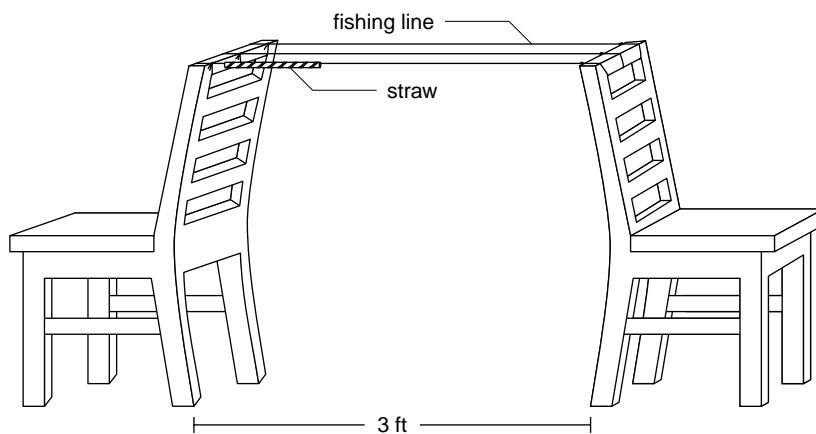

6. Blow up a balloon. Do not tie off the end. With masking tape, attach the balloon to the straw threaded on the string so that the open end of the balloon is facing the end of the string (see figure 2).
7. Let go of the balloon. Measure the distance the balloon moved and record the distance on the data table.
8. Repeat for the other balloons.
9. Average the results, and record the average on the data table.
10. Would a smaller balloon move the straw further?

**Figure 2**

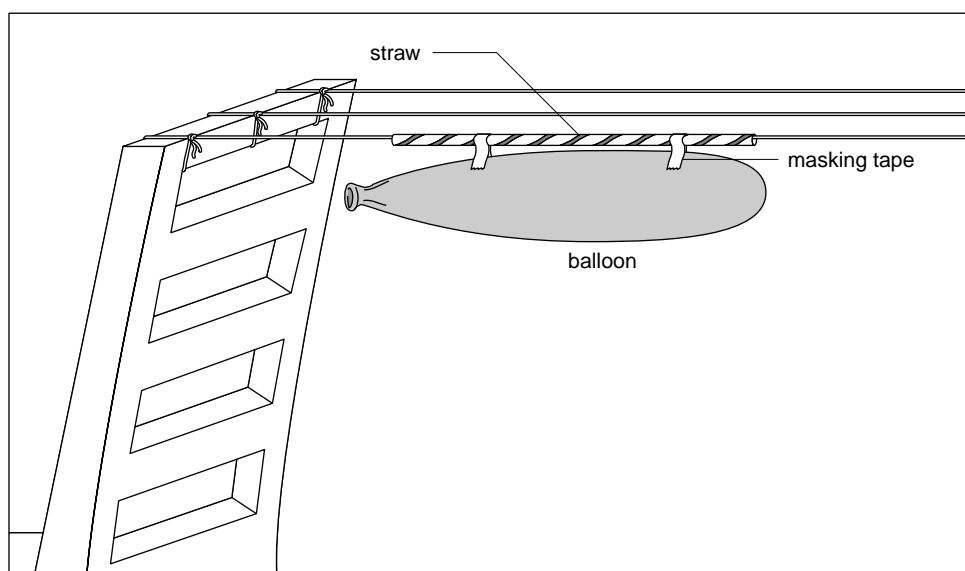

#### What's Going On

When the balloon is first blown up and held closed, all forces inside are kept constant or balanced. When you release the balloon, you disturb the balance, and one force is removed; therefore the opposite force takes place. Newton's third law states that when a body exerts a force on a second body, an equal and opposite force is exerted on the first body: For every action there is an equal and opposite reaction.

#### Connection

This experiment simulates the action of a rocket or satellite. Rockets move because hot gases are forced out the back of the rocket. You have seen rockets during July 4th celebrations. The fireworks expert lights the rocket, which is propelled into the sky and explodes.

#### Troubleshooting

The further the chairs are from each other, the better the results. Pull the string tightly so that it does not droop.

Additional Activities

Take a small, empty, plastic water bottle. Put a thin straw inside the bottle so that it is about 3 in. within the bottle (figure 3). Stopper the bottle and straw with modeling clay. Make a simulated rocket by taking a larger-diameter straw and taping two paper loops to the straw, one on one end, the other on the other end. The loops should be facing the same direction. Place the rocket simulator over the straw in the bottle. Stopper the rocket simulator straw with modeling clay. Squeeze the bottle quickly!

Figure 3

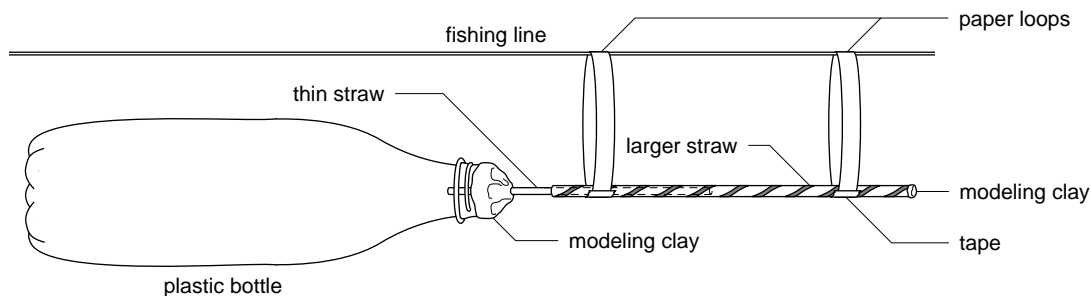

| DATA TABLE |                       |
|------------|-----------------------|
| Balloons   | Distance traveled, ft |
| 1          | _____                 |
| 2          | _____                 |
| 3          | _____                 |
| Average    | _____                 |